

TNZ Thüringische Nadelfertigung  
Elvira Ziggel  
Stadtilmer Str. 80  
99310 Wüllersleben



Telefon: +49 36200 64495  
Mobil: +49 172 3619401  
Telefax: +49 36200 60357  
E-Mail: [tnz.ziggel@t-online.de](mailto:tnz.ziggel@t-online.de)

---

## steel pins for spinning preparation and spinning machines

---

### Gill pins

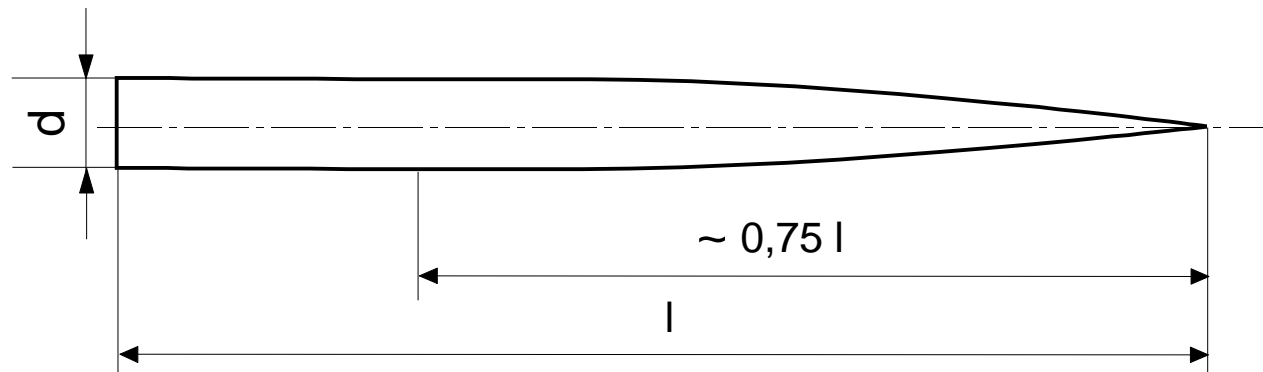

### Carding pins

---

TNZ Thüringische Nadelfertigung  
Elvira Ziggel  
Stadtilmer Str. 80  
99310 Wüllersleben



Telefon: +49 36200 64495  
Mobil: +49 172 3619401  
Telefax: +49 36200 60357  
E-Mail: [tnz.ziggel@t-online.de](mailto:tnz.ziggel@t-online.de)

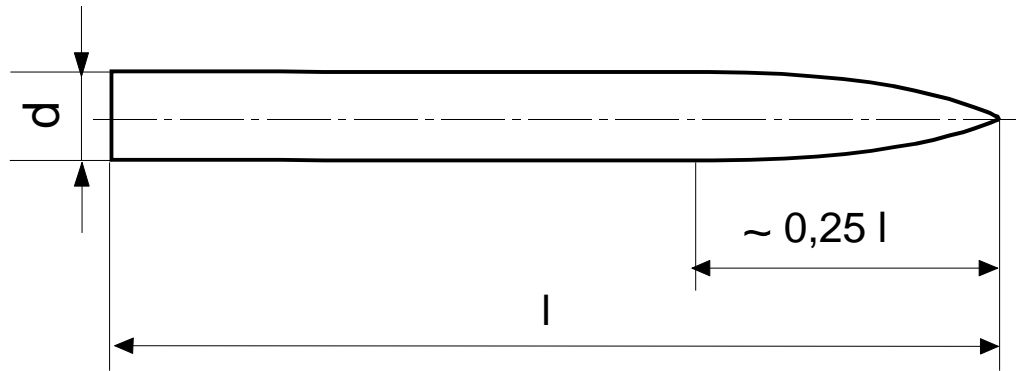

### Comb pins

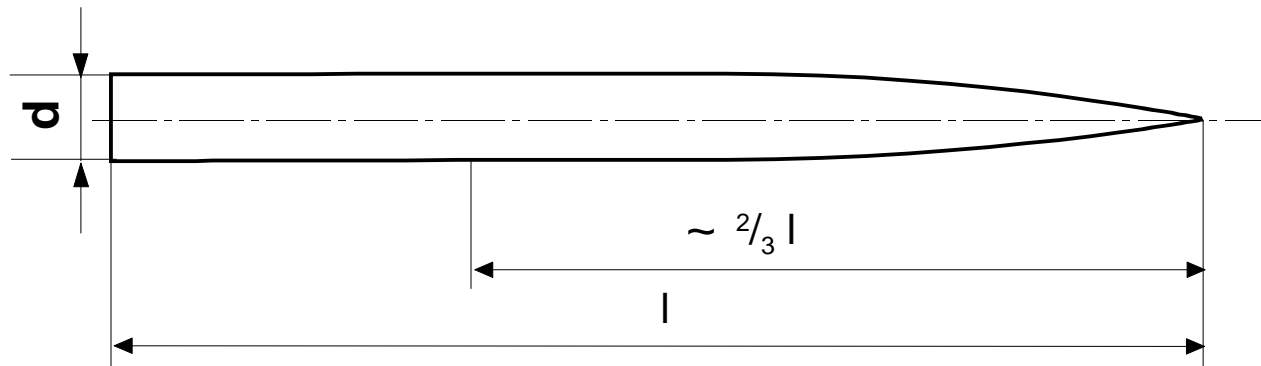

**TNZ Thüringische Nadelfertigung**  
Elvira Ziggel  
Stadtilmer Str. 80  
99310 Wüllersleben



**Telefon: +49 36200 64495**  
**Mobil: +49 172 3619401**  
**Telefax: +49 36200 60357**  
**E-Mail: [tnz.ziggel@t-online.de](mailto:tnz.ziggel@t-online.de)**

## Hackle pins

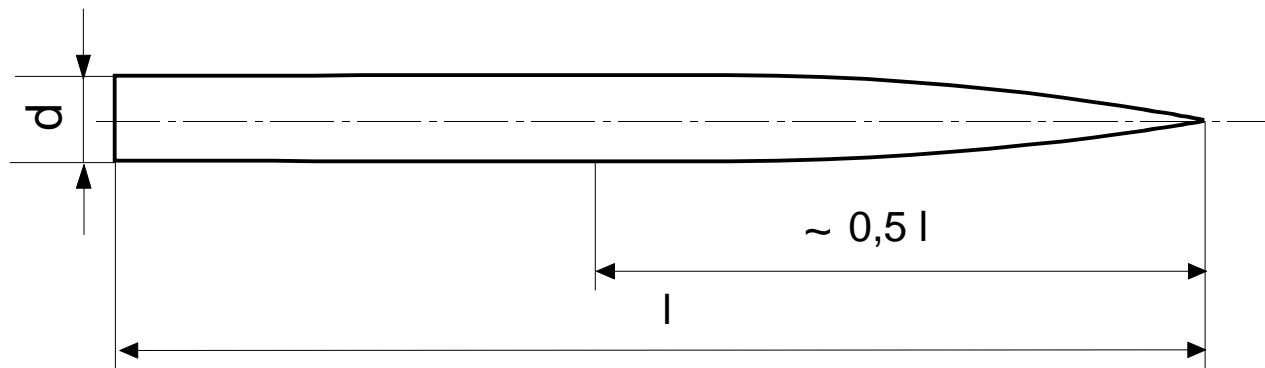

## temple pins

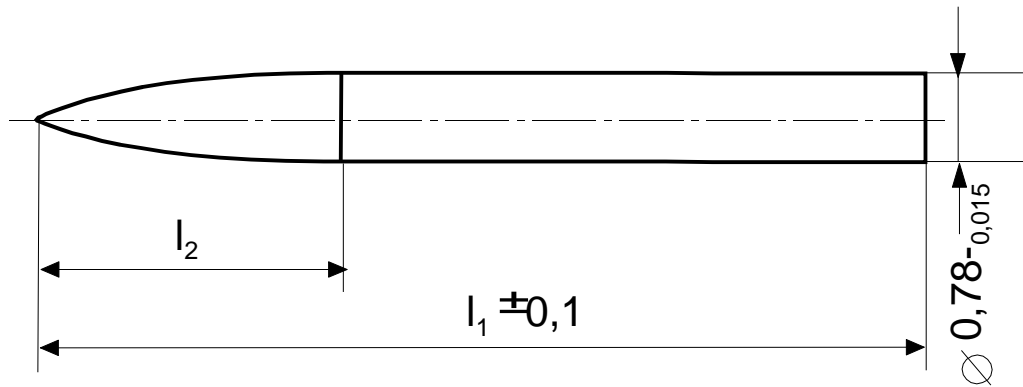

$l_1$	2,75	3	3,25	3,5	3,75	4	4,25	4,5	4,75	5	5,25	5,5	5,75
$l_2$	1,5	1,75		2	2,25	2,5				2,75			



---

## Steel pins for spinning preparation and spinning machines

---

### Round pins with notch

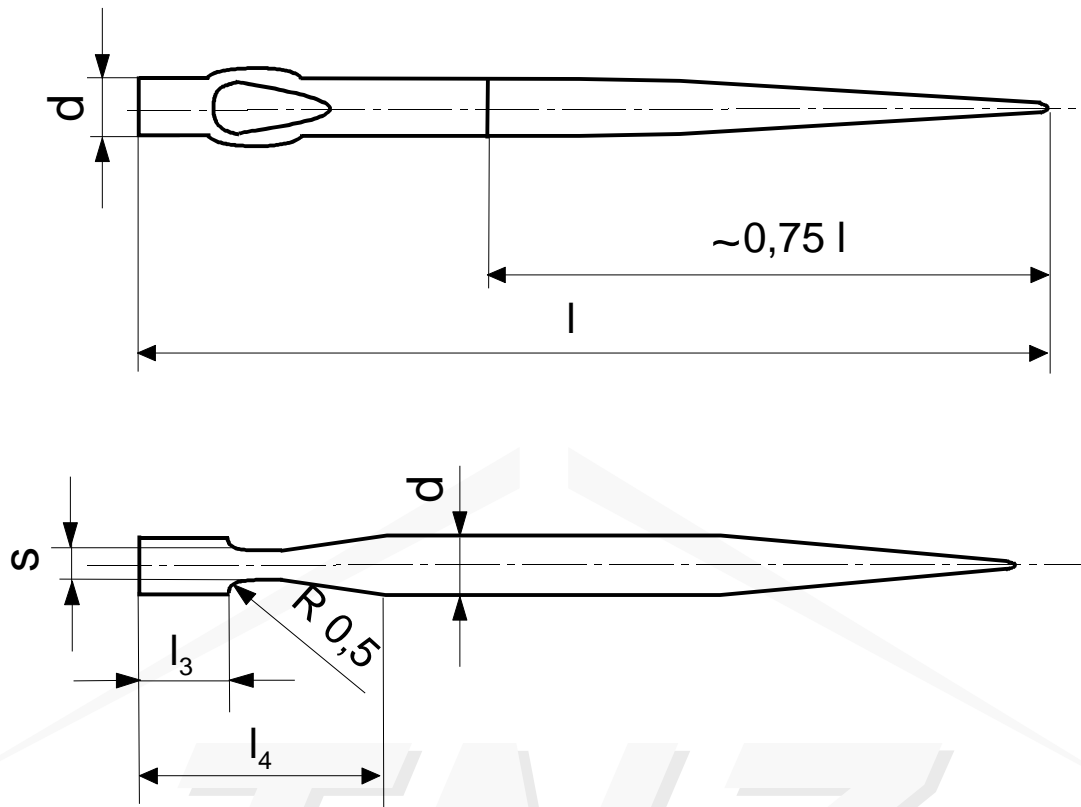

## Steel pins for spinning preparation and spinning machines

### Flat pins

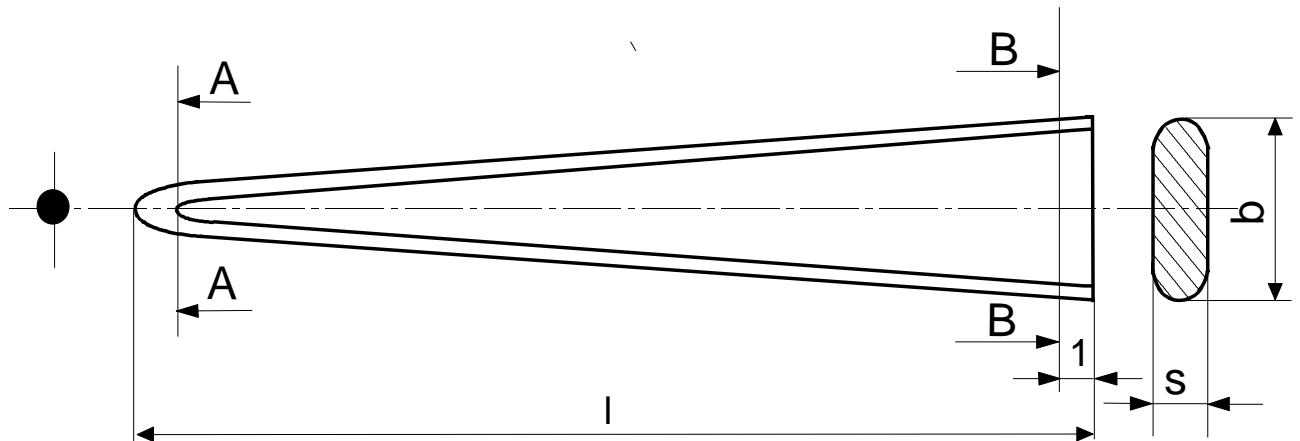

## Steel pins for spinning preparation and spinning machines

### Flat pins with shaft

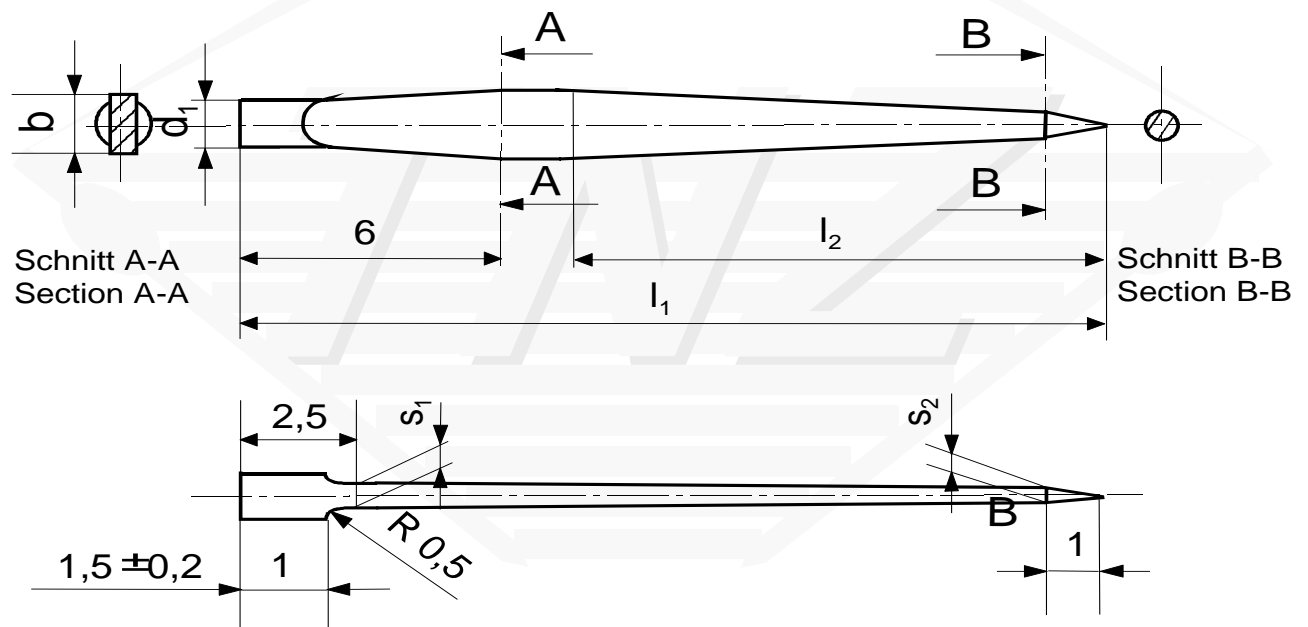

## Wool combing machines NSC PB26-29/PB30-33, P90/100, Textima pin strips for circular combs

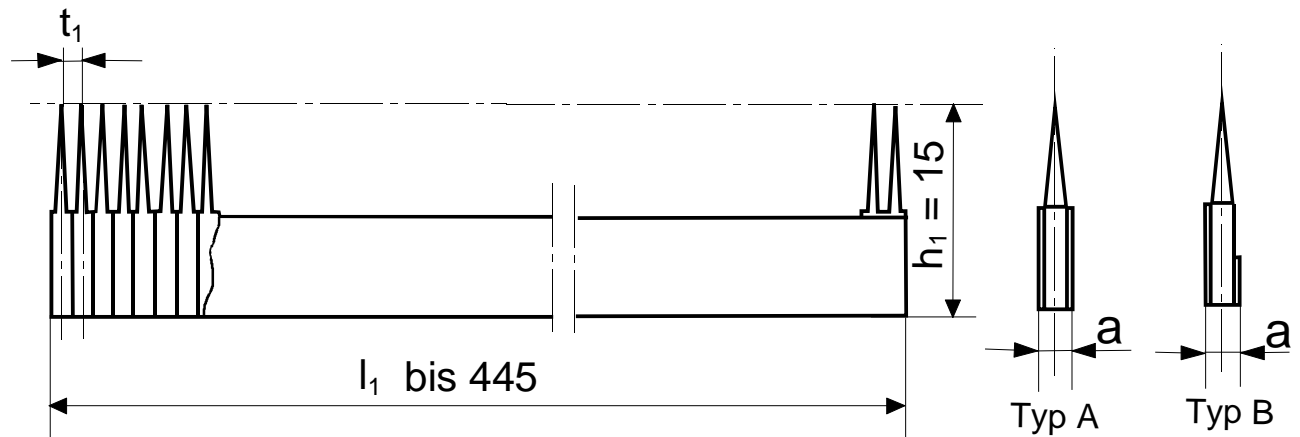

pins/cm	a		NSC	NSC	SAN	Textim
	Typ A	Typ B	PB26-PB29	PB30-PB33	P90-P100	a
4	2,0	2,5	430	440	430	445
6	2,0	2,5	430	440	430	445
7	2,0	2,5	430	440	430	445
8,5	2,0	2,5	430	440	430	445
10	2,0	2,5	430	440	430	445
11	2,0	2,5	430	440	430	445
12	2,0	2,5	430	440	430	445
14,2	2,0	2,5	430	440	430	445
14,1	1,0	1,5	430	440	430	445
15	1,0	1,5	430	440	430	445
16	1,0	1,5	430	440	430	445
17	1,0	1,5	430	440	430	445
18	1,0	1,5	430	440	430	445
19	1,0	1,5	430	440	430	445
20	1,0	1,5	430	440	430	445
21	1,0	1,5	430	440	430	445
22	1,0	1,5	430	440	430	445
23	1,0	1,5	430	440	430	445
24	1,0	1,5	430	440	430	445
25	1,0	1,5	430	440	430	445
26	1,0	1,5	430	440	430	445
27	1,0	1,5	430	440	430	445
28	1,0	1,5	430	440	430	445

**TNZ Thüringische Nadelfertigung**  
**Elvira Ziggel**  
Stadtilmer Str. 80  
99310 Wüllersleben



**Telefon: +49 36200 64495**  
**Mobil: +49 172 3619401**  
**Telefax: +49 36200 60357**  
**E-Mail: [tnz.ziggel@t-online.de](mailto:tnz.ziggel@t-online.de)**

---

<b>29</b>	1,0	1,5	430	440	430	445
<b>30</b>	1,0	1,5	430	440	430	445
<b>31</b>	1,0	1,5	430	440	430	445
<b>32</b>	1,0	1,5	430	440	430	445

**Example of order**

Type of machine      NSC PB 28  
Variant                Typ B  
Pins/cm                30 N/cm  
Needle field           430 mm





## Wool combing machines pin strips for top combs

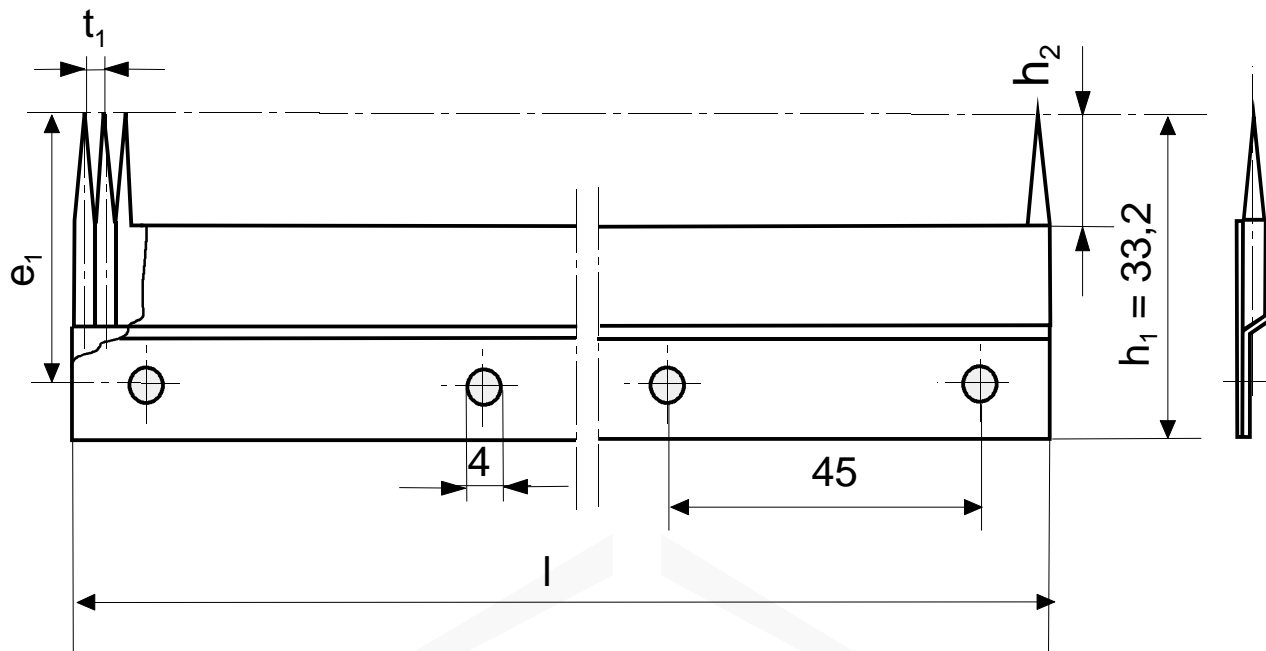

pins/cm	NSC	NSC	SAN	Textima
	PB26-PB29 Needle field	PB30-PB33 Needle field	P90-P100 Needle field	Needle field
<b>16</b>	470	470	460	460
<b>18</b>	470	470	460	460
<b>21</b>	470	470	460	460
<b>23</b>	470	470	460	460
<b>25</b>	470	470	460	460
<b>26</b>	470	470	460	460
<b>28</b>	470	470	460	460
<b>30</b>	470	470	460	460
<b>32</b>	470	470	460	460
Pin taper	8,2	8,2	8,2	8,2
	9,2	9,2	9,2	9,2
	10,2	10,2	10,2	10,2

### Example of order

Type of machine	NSC PB 28
System	top combs
Pin taper	8,2
Pins/cm	30 N/cm
Needle field	470 mm